

LUBRI/STAT[®] SPRAY BOOTH SYSTEM

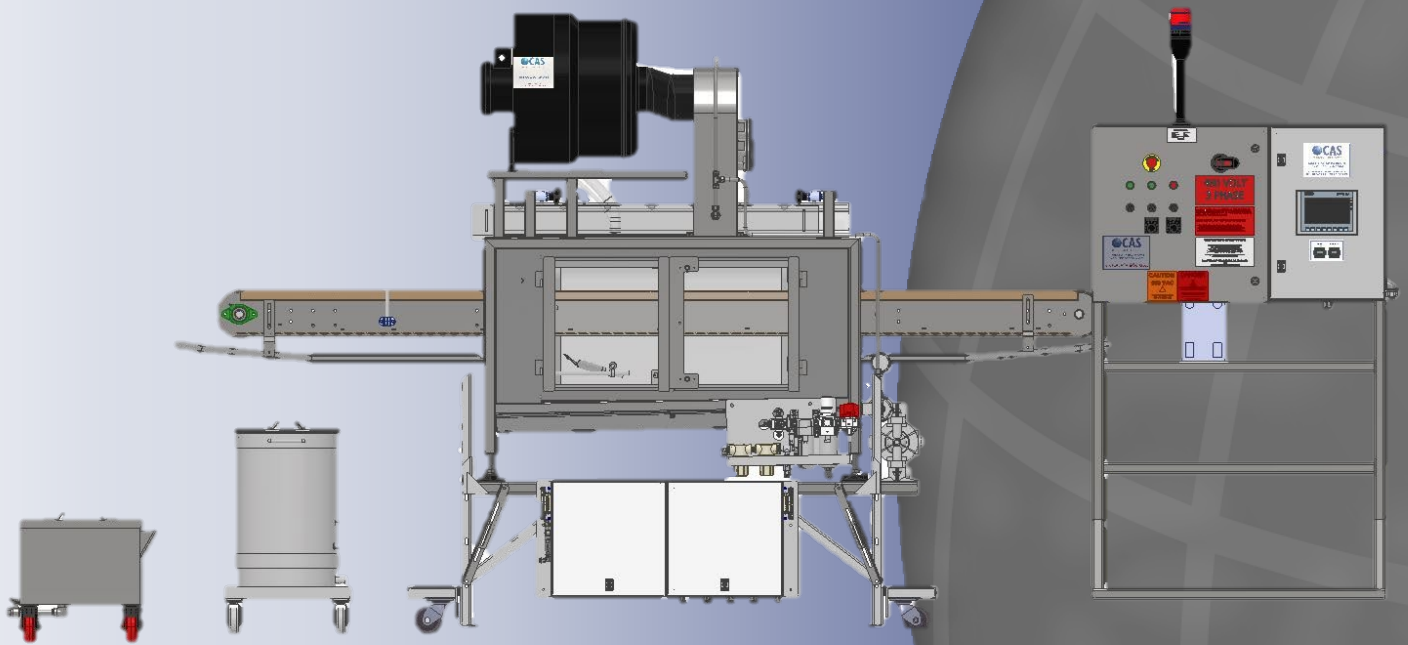

**Simple, cost effective on-line ultrasonic spray coating
to dramatically reduce container static & external
scuffing & improve bottle handling**



CONTAINER AUTOMATION SYSTEMS

PO BOX 2850 CUMMING, GA 30028

PHONE (678)-947-5656 • FAX (678)-947-5655

www.containerautomationsystems.com

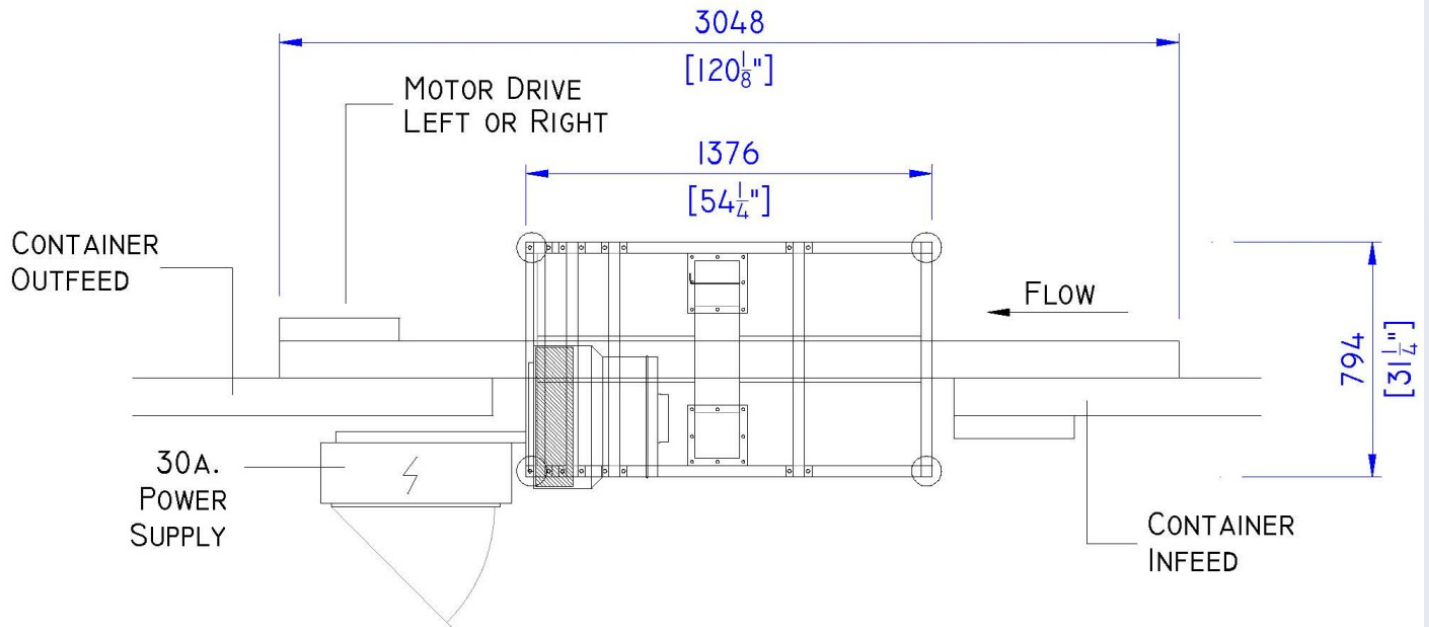

LUBRI/STAT® APPLICATION SYSTEM FEATURES

- Stainless steel construction
- Ultrasonic spray nozzle keeps spray material & air consumption to a minimum.
- Unit incorporates a mist collector with independent filtration system to collect unused material.
- Optional flow monitoring ensures optimum material application and minimal usage.
- Optional system components include: central mixing system and water treatment system.
- Compatible with CAS downstream handling, packing, palletizing & testing equipment.

LUBRI/STAT® SPRAY MATERIAL BENEFITS

- Reduces static charge in pet containers from 1000+ volts to almost 0.
- Dramatically reduces exterior bottle wall scuffing by a factor of 8x.
- Minimizes dust & foreign material attraction.
- Improves container handling and reduces filling-line blockages.
- Enhances visual appeal of containers with less scuffing, dust accretion and dry product cling on internal surfaces.
- All CAS equipment is covered by copyright design.

CONTAINER AUTOMATION SYSTEMS

PO BOX 2850 CUMMING, GA 30028

PHONE (678)-947-5656 • FAX (678)-947-

5655

