

# AUTO TRAY PACKING UNIT

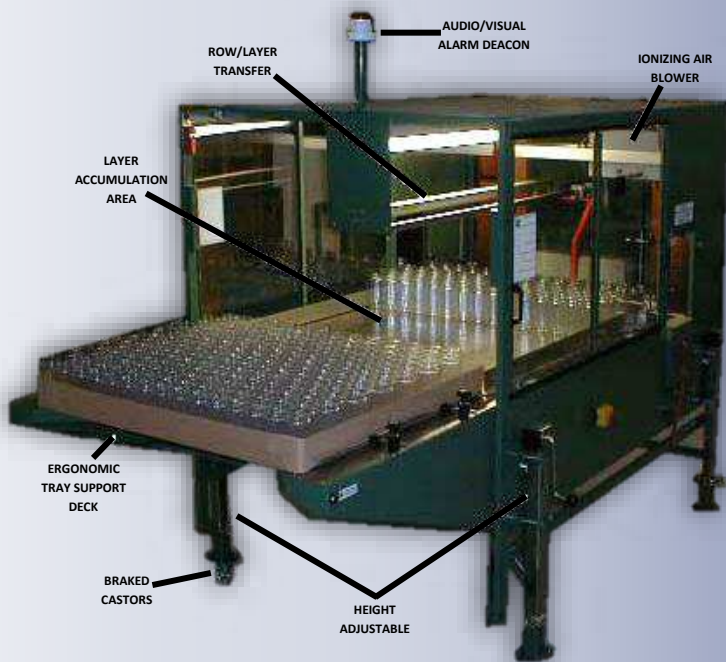

Cost-effective and simple automatic tray packing of round, square, oval, and irregular size shaped containers



**CONTAINER AUTOMATION SYSTEMS**

PO BOX 2850 CUMMING, GA 30028

PHONE (678)-947-5656 • FAX (678)-947-5655

[www.containerautomationsystems.com](http://www.containerautomationsystems.com)

# BENEFITS & FEATURES

- Minimal operator involvement (approx. 20 seconds per tray load) to place tray, press reset button and remove loaded tray.
- Fully automatic control and monitoring functions with 'tray full' warning strobe and machine status-indicator lights.
- Handles any container size and most shapes, packing uniform or staggered row configurations up to 3500 containers per hour.
- Simple change parts and panel-mounted counter setting for product change over.
- Interlocked, sliding access doors ensure product cleanliness and operator safety without degrading unit effectiveness.
- Machine accumulation capacity up to two tray loads, can be easily transferred in one operation.
- Compact, automatic transfer of containers from marshalling area onto the tray.
- Container transfer onto the in-feed conveyor from either side, with optional CAS on-line leak & vision testers.
- Low consumption supply requirements: 1-phase 230/110vac 50/60hz 0.5kw 0.5 CFM 80psi (5.5 bar)
- Unit constructed to suit any tray size / orientation
- Optional support frame configurations including bi-directional in feed conveyor, height adjustment and mobility features to accommodate different production line layouts, plus layer inversion facility
- All CAS equipment is covered by copyright design

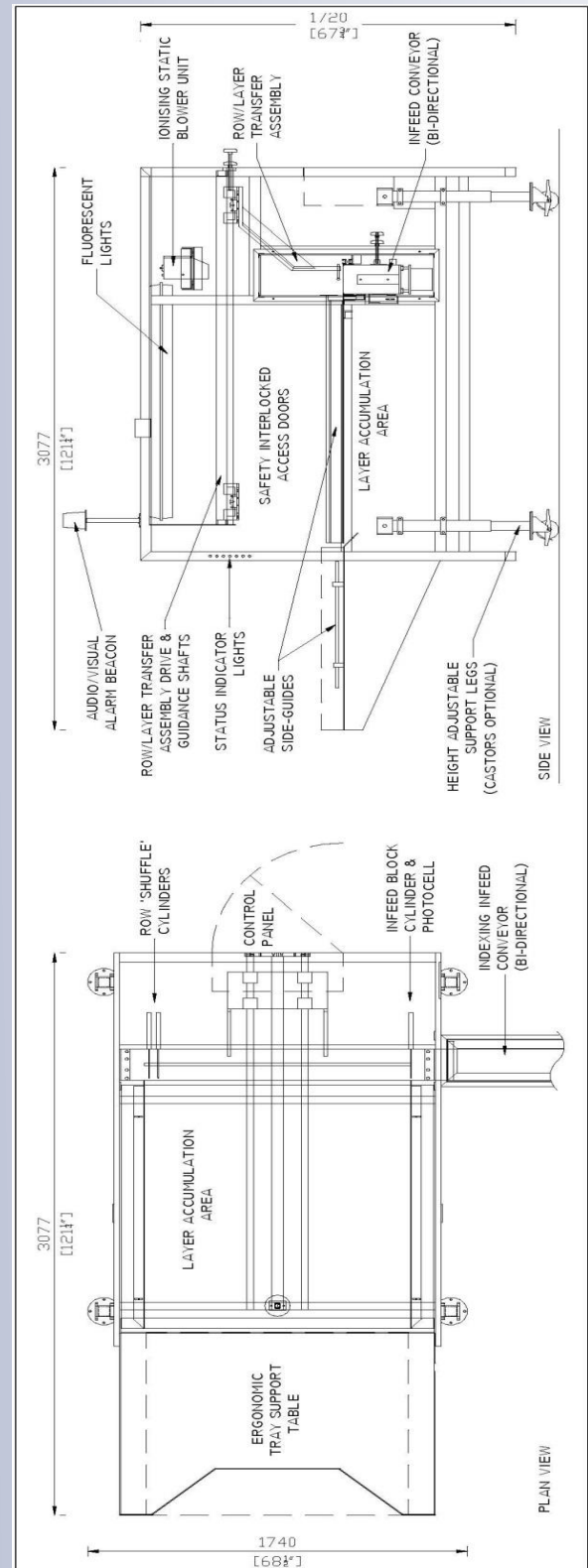

## CONTAINER AUTOMATION SYSTEMS

PO BOX 2850 CUMMING, GA 30028

PHONE (678)-947-5656 • FAX (678)-947-5655

www.containerautomationsystems.com

